

The information contained in this drawing is the sole property of CWS Coil Winding Specialist. Any reproduction in part or whole without written permission of CWS Coil Winding Specialist is prohibited.

REVISION HISTORY			
REV	ECN	DESCRIPTION	DATE
A		PRODUCTION RELEASE	12/11/04

VERTICAL MOUNT  
 .53 [1.35] Max

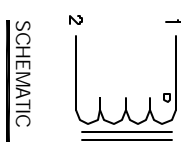
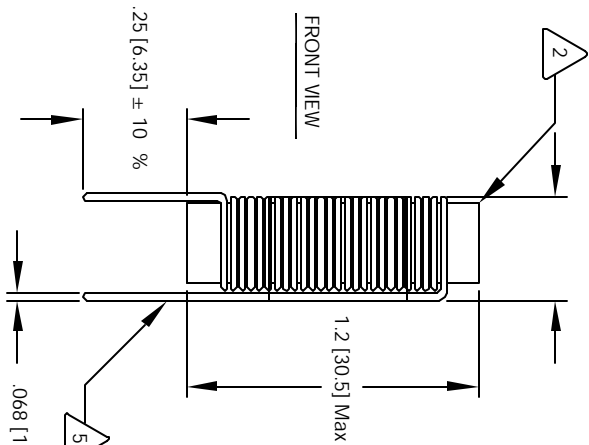

- INDUCTANCE DROPS 10% FROM ZERO ADC VALUE SATURATION CURRENT IS THE CURRENT AT WHICH THE TEMP. RISE ABOVE AMBIENT OF 25 °C.
- MAX DC CURRENT IS AVERAGE CURRENT FOR 40 °C NOTES:
- LEADS MUST BE TANGENT TO THE CORE
- .05" ABOVE THE CORE EDGE, AND
- REMOVE INSULATION AND TIN LEADS

- WIND COILS EVENLY SPACED
- CONSTRUCTION:

MAX TEMP RISE AT MAX CURRENT = 40 °C  
 HI-POT TEST FOR CORE TO WINDING = 500 VDC  
 DCR = 4 MILLI-OHMS MAX @ 25 °C  
 SATURATION CURRENT = 20 AMPS  
 L = 4.7 uH ± 15% . 15.75 KHZ, 0.1 Vrms, 0 ADC;  
 SPECIFICATIONS: MAX RMS (DC) CURRENT = 20 AMPS

- 1 MATERIAL: WIRE INSULATION - UL RECOGNIZED 94V-0 FOR FLAMMABILITY
- 2 WIRE: UL RECOGNIZED 130°C RATED MAGNET WIRE  
 CWS BYTE-MARK OR OTHER APPROVED PART  
 CORE: MANGANESE ZINC FERRITE ROD

RATING CLASS B (130°C) REQUIRED  
 NOTES: UNLESS OTHERWISE SPECIFIED, POWER INDUCTOR, DIMENSIONS IN INCHES [MM]. READ FROM BOTTOM UP

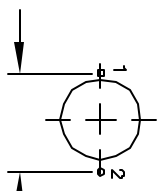

Mounting Holes Pattern

CODE IDENT	MFG. P/N	DESCRIPTION	ITEM NO.
AUTOCAD SOLIDWORKS SIGN	X	PARTS LIST	
DATE	DATE	CWS Coil Winding Specialist 1510 E. Edinger Ave Unit B, Santa Ana, CA 92705	
12/11/04	12/11/04	Power Chokes Vertical Mount	
APPR. JLAU	12/11/04	SIZE DIM. IN. B	REV A
		SCALE 2=1	SHEET 1 OF 1